

COMPRESSEUR HYDRAULIQUE

Compresseur hydraulique

- Tension moteur : 12-24V
- Cylindrée compresseur : 145cc
- Réfrigérant compresseur: R134a
- Type de raccord O-Ring
- Lubrifiant compresseur : PAG56
- Charge d'huile initiale compresseur : 160 cc
- Vanne de commande hydraulique non fournie

Hydraulic compressor

- Motor Voltage: 12-24V
- Compressor displacement: 145cc
- Compressor R134a coupler ports
- O-Ring fitting type
- Compressor lubricant : PAG56
- Compressor initial oil charge : 160 cc
- Hydraulic command valve not supplied

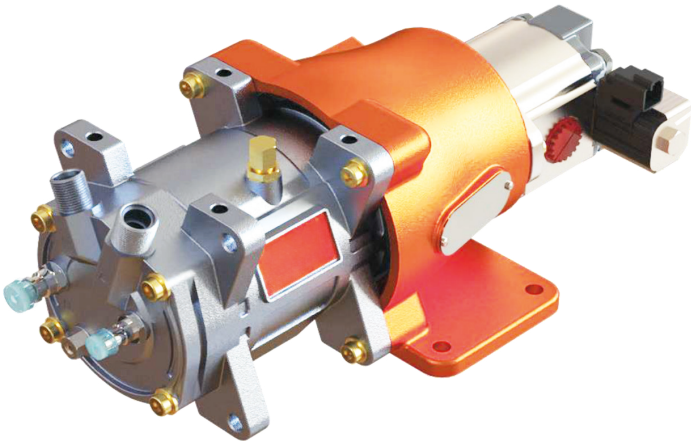

VISUEL NON CONTRACTUEL

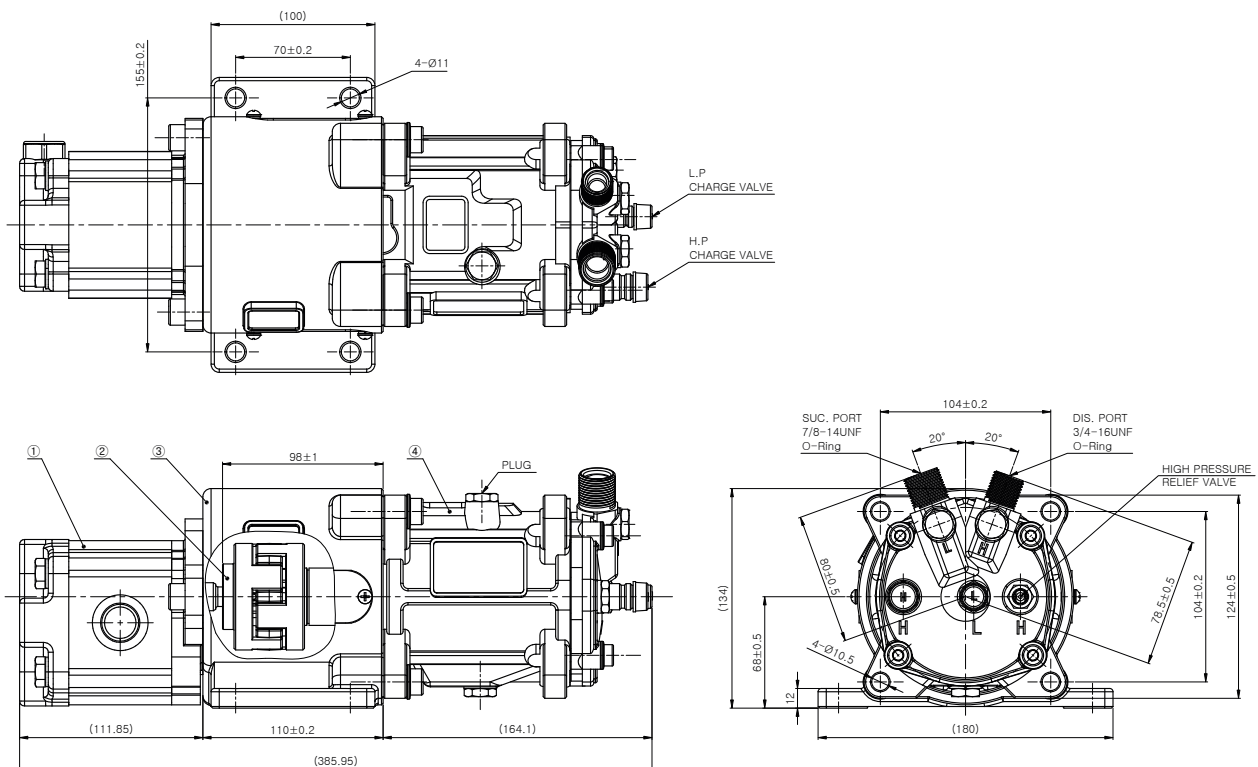

Type	Référence	Tension moteur	Pression Max. Moteur	Cylindrée	Tours par minute max.
Type	Reference	Motor voltage	Motor Max. Pressure	Capacity	Max. RPM
UPH150	0400 1200	12-24V	250 bars	145cc (compressor) 14cc (hydraulic motor)	6000 RPM (compressor) 3000 RPM (hydraulic motor)