

CONDENSEUR CIERZO 8 kW



Condenseur Cierzo 8 kW

- Disponible en 12V ou 24V
- Technologie Parallel Flow
- Puissance frigorifique : 8.1 kW
- Raccords à visser O-ring
- Livré avec connecteur
- Livré avec ou sans filtre déshydrateur

8 kW Cierzo Condenser Unit

- Voltage 12V or 24V
- Parallel Flow technology
- Cooling capacity: 8.1 kW
- O-ring connection
- Supplied with connector
- Delivered with or without receiver drier

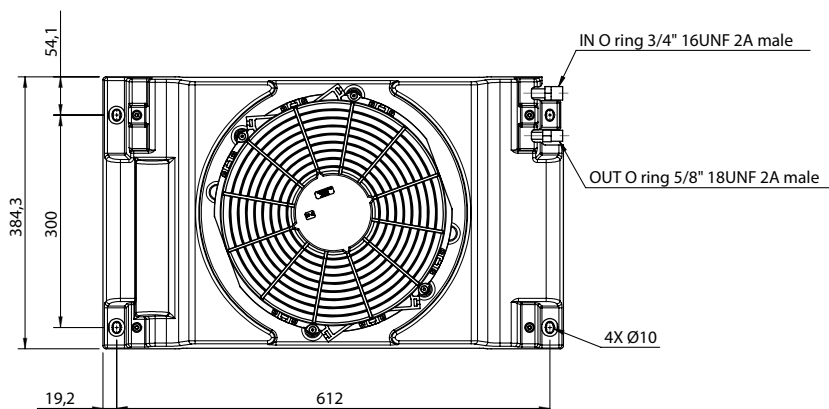
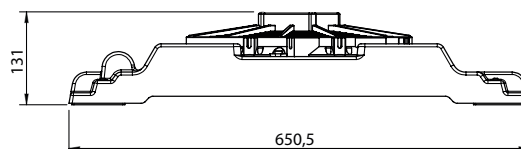
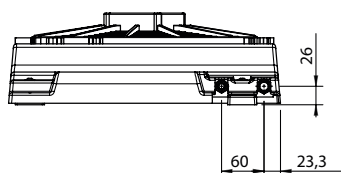

Type Type	Référence / Reference	
	12 V	24 V
CIERZO SANS FILTRE DESHYDRATEUR / CONDENSER WITHOUT RECEIVER DRIER	0327 0036	0327 0037
CONDENSEUR AVEC FILTRE DESHYDRATEUR / CONDENSER WITH RECEIVER DRIER	0327 0038	0327 0039

Tension Voltage	Puissance électrique Electrical power	Poids Weight	Débit d'air nominal Nominal air flow	Puissance dissipée Dissipated power
12 V	196 W	3 kg	1940 m³/h	8.1 kW
24 V	170 W		1820 m³/h	