

BOREAL F92 HVAC & EVAP



EVAP



HVAC

2 versions : climatisation ou combiné chauffage climatisation

- Ventilation 3 vitesses
- Tension d'alimentation : 12V ou 24V
- Version HVAC : raccordement Ø16mm
- Corps en ABS
- Thermostat « anti-givre » intégré
- Détendeur pour raccords à visser O-ring
- Disponible avec des diffuseurs d'air Sensyo® 92 en métal/black ou en noir
- Livré avec kit d'installation et connecteur

2 versions: air conditioning or heating & air conditioning unit

- 3 speed ventilation
- Voltage: 12V or 24V
- HVAC version: Ø16mm hose diameter
- ABS body
- Including "anti-freezing" thermostat
- Expansion valve O-ring connection
- Available with black or metal/black Sensyo® 92 air diffusers
- Supplied with mounting kit and connector

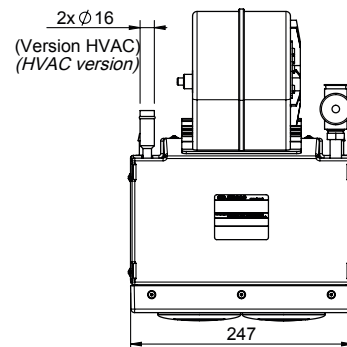
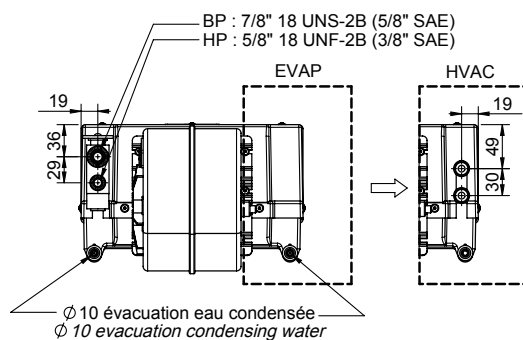
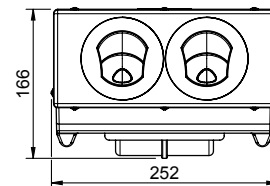
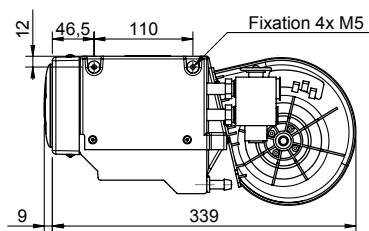
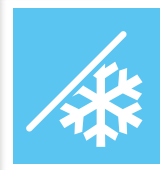

Type Type	Référence / Reference	
	12 V	24 V
BOREAL F92 HVAC NOIR d16 3V	0330 0010	0330 0011
BOREAL F92 HVAC METAL / BLACK d16 3V	0330 0012	0330 0013
BOREAL F92 EVAP NOIR 3V	0330 0110	0330 0111
BOREAL F92 EVAP METAL / BLACK 3V	0330 0112	0330 0113

Type Type	Tension Voltage	Puissance électrique Electrical power	Poids Weight	Débit d'air nominal Nominal air flow	Puissance calorifique Heating capacity	Puissance frigorifique* Cooling capacity
					Ethylene glycol	
HVAC	12/24 V	130 W	3,5 kg	250 m³/h	3,7 Kw	2,7 kw
EVAP	12/24 V	130 W	3,5 kg	250 m³/h	-	3,8 kw

*Valeurs de calcul P.53 / Calculating values P.53