

MINOX 12 B



Chauffage à eau à grande capacité aéraulique

- 3 vitesses de ventilation
- Tension d'alimentation : 12V ou 24V
- Raccordement Ø16mm
- Les sorties des tubes radiateur peuvent être à droite ou à gauche
- Livré avec connecteur

High air flow water heater

- 3-speed fan
- Voltage: 12V or 24V
- Ø16mm hose diameter
- The heater coil pipes can be mounted on the right side or on the left side
- Supplied with connector

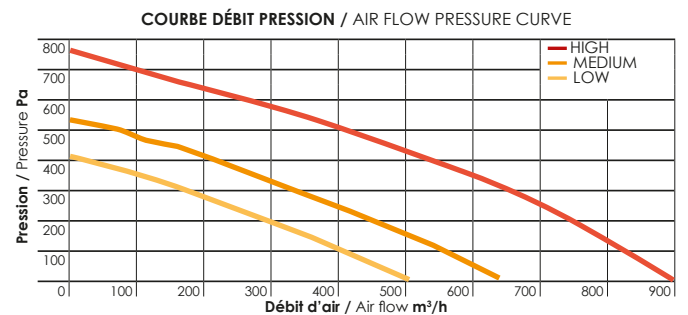
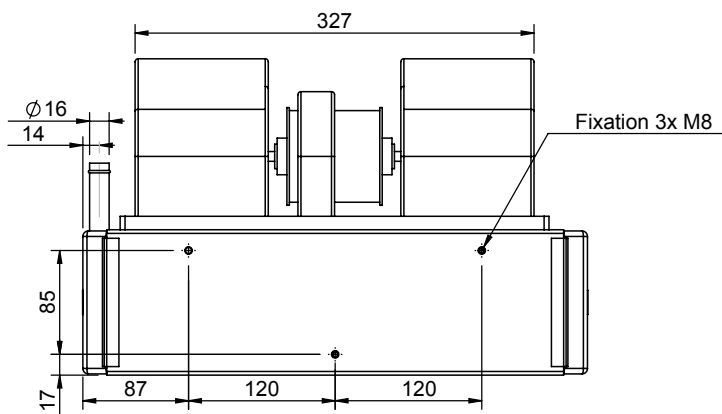
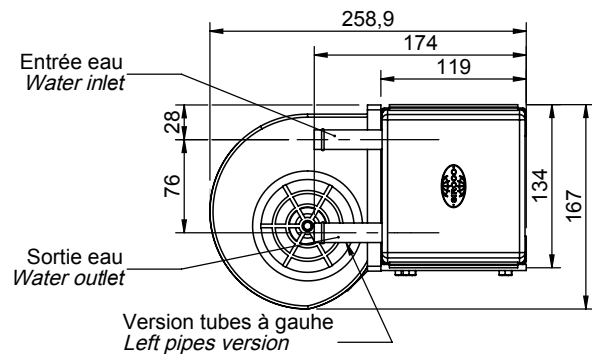
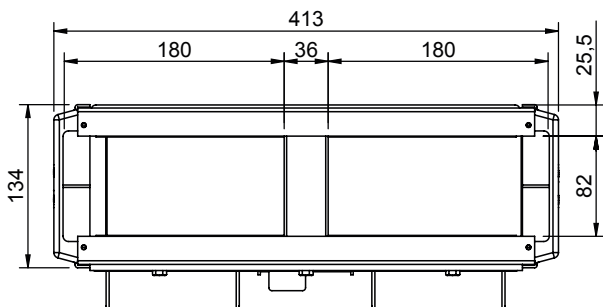

Tension Voltage	Ø tube / pipe mm	Minox 12 B Reference
12 V	16	0130 3114
24 V	16	0130 3116

Tension Voltage	Puissance électrique Electrical power	Poids Weight	Débit d'air nominal Nominal air flow	Puissance calorifique* Heating capacity
				Ethylene glycol
12/24 V	250 W	4,6 kg	800 m³/h	12,6 kW

*Conditions et paramètres de calculs P. 9 / Conditions and calculation parameters P. 9