

# TENERE II B



## Chauffage à eau

- 2 ou 3 vitesses de ventilation
- Tension d'alimentation : 12V ou 24V
- Raccordement Ø16mm - option Ø14mm
- Corps en polypropylène
- Sorties des tubes radiateur à droite ou à gauche
- Grille de protection d'entrée d'air sur la version standard
- Accessoire manchon d'entrée d'air en option (Ø40 à Ø70mm)

## Water heater

- 2 speed or 3 speed fan
- Voltage: 12V or 24V
- Ø16mm hose diameter - Ø14mm option
- Polypropylene body
- Heater coil pipes mounted on the right or on the left side
- Protective grid fan air inlet on standard version
- Optional sleeve fan air inlet equipment (from Ø40 to Ø70mm)



**SLEEVE  
OPTION**



**PROTECTIVE GRID**

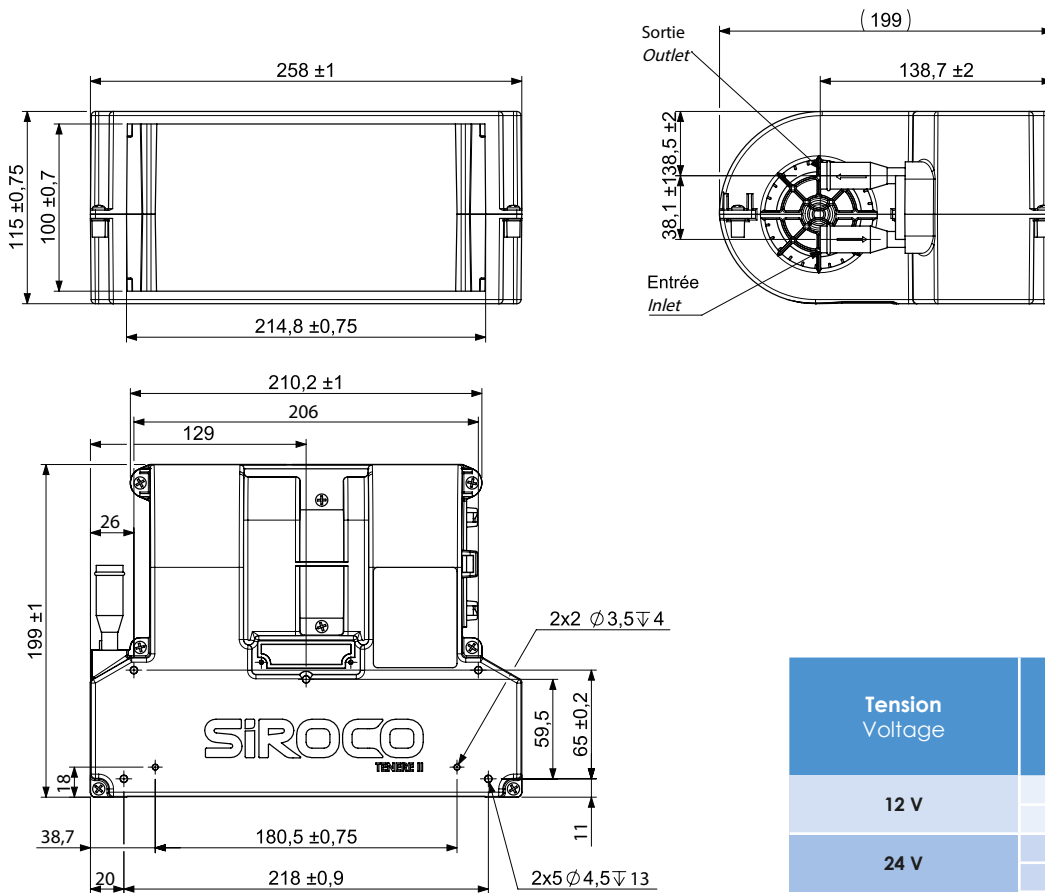

Tension Voltage	Vitesses Speeds	TENERE II B Référence
12 V	2	0160 0002
	3	0160 0006
24 V	2	0160 0001
	3	0160 0005

Type	Tension Voltage	Puissance électrique Electrical power	Poids Weight	Débit d'air nominal Nominal air flow	Puissance calorifique* Heating capacity
					Ethylene glycol
TENERE II B	12/24 V	65 W	1,6 kg	265 m³/h	4,2 kW

\*Conditions et paramètres de calculs P. 9 / Conditions and calculation parameters P. 9